

Clean Air Gun™ Series

400, 600 Amp MIG Guns

Issued Nov. 2009 • SPEC CA-1.6

400 Amp Clean Air Gun™



Bernard Clean Air Guns™ help create an efficient shop with reduced smoke and fumes regardless of your operation.

All Guns are Not Created Equal.

A MIG gun should be durable, easy to use and customized to your specific application. Our MIG guns put you in control: you choose the options you need and we'll build a gun to last.

Heavy-duty handles for durability.

45 degree bend for maximum feeding characteristics.

Chrome parts to resist spatter adhesion.

Adjustable vacuum chamber maximizes suction without affecting shielding gas and provides for efficient smoke collection.

Ideally suited for almost any heavy-duty MIG welding application.

Compatible with Centerfire™ series consumables for better arc starts, less spatter, more consistent welds and longer tip life.

Made with
Pride and without
Compromise in the **USA**

Clean Air Gun Part Number- 400 Amp

Amperage	Cable Length	Contact Tip Style and Wire Size	Direct Plug
CA4	10 10' (3.05 m)	A Elliptical, 7400 series, 1.25" long .045" (1.2 mm)	M Miller®
	15 15' (4.57 m)	B Elliptical, 7400 series, 1.25" long 1/16" (1.6 mm)	B Bernard®
	25 25' (7.63 m)	D Centerfire .045" (1.2 mm)	
		E Centerfire 1/16" (1.6 mm)	

Clean Air Gun Part Number- 600 Amp

Amperage	Cable Length	Contact Tip Style and Wire Size	Direct Plug
CA6	10 10' (3.05 m)	A Elliptical, 7400 series, 1.25" long .045" (1.2 mm)	M Miller®
	15 15' (4.57 m)	B Elliptical, 1500 series, 2.00" long HD 1/16" (1.6 mm)	B Bernard®
	25 25' (7.63 m)	C Elliptical, 1500 series, 2.00" long HD 3/32" (2.4 mm)	
		D Centerfire .045" (1.2 mm)	
		E Centerfire 1/16" (1.6 mm)	
		F Centerfire 3/32" (2.4 mm)	

Note: A minimum of 70 CFM @ 35" H₂O of air flow is required for efficient operation.

Bernard®

An Illinois Tool Works Company
449 West Corning Road, Box 667
Beecher, Illinois 60401 USA

Phone: 800-946-2281 (US Only) 708-946-2281 (Outside US)
Fax: 708-946-6726
For more information, visit us at BernardWelds.com



Replacement Parts List

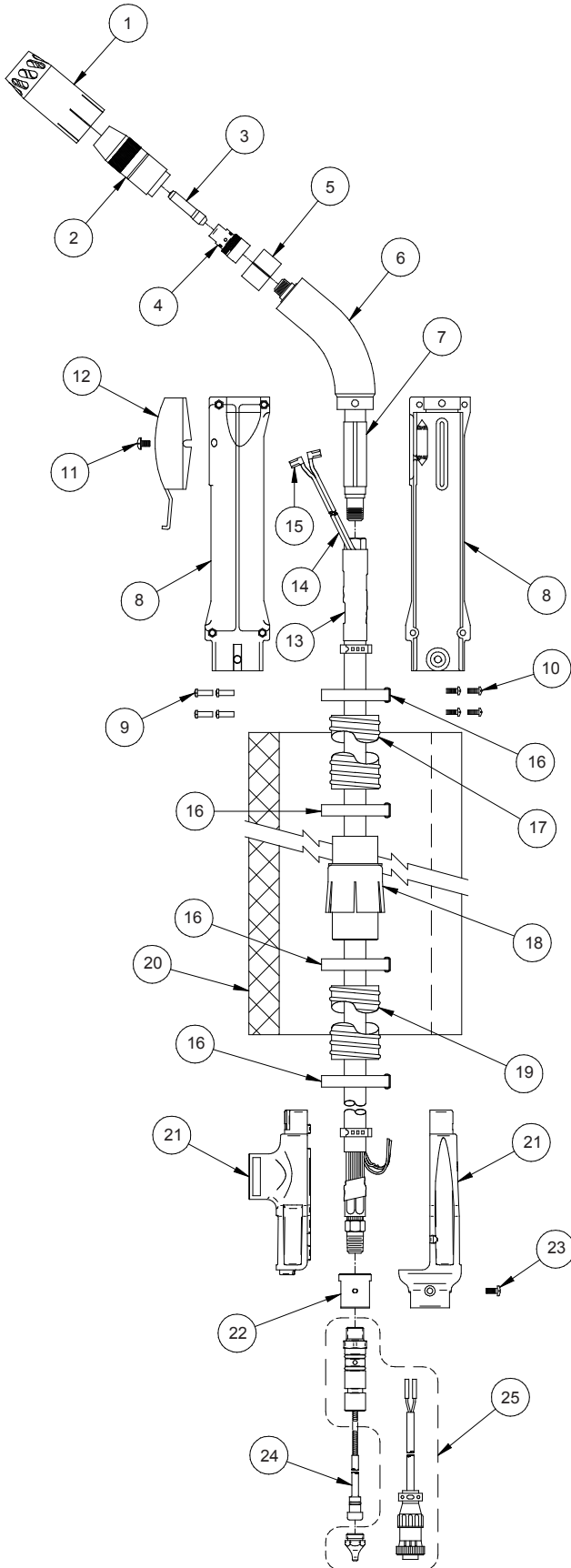

ITEM #	400A PART #	600A PART #	DESCRIPTION
1	1390006	1390008	Vacuum Chamber, Elliptical
	1390090	1390091	Vacuum Chamber, Centerfire
2	<i>See Centerfire Spec Sheet</i>		Nozzle Assy
3	<i>See Centerfire Spec Sheet</i>		Contact Tip
4	<i>See Centerfire Spec Sheet</i>		Gas Diffuser
5	2460016	2460015	Spacer
6	2390002	2390001	Vacuum Tube
7	1040049		Body Tube
8	1880037		Handle Kit (Includes: (4) #9, (4) #10, (2) #11, (1) #16)
9	4207		Post Fastener (4 Req'd)
10	4209		Screw (4 Req'd)
11	418		Trigger Screw (2 Req'd)
12	422		Trigger Assy
13	9096		Shrink Tube
14	1130016		Lead Set
15	457		Flag Terminal
NS	4932		Butt Connector
16	1520011		Clamp Headless (4 Req'd)
17	1800012		Vacuum Hose, Front
18	1880036		Swivel Kit (Includes: (2) #16)
19	1800011		Vacuum Hose, Rear (Order same length as gun: 10' for 10' gun, etc.)
20	1860005		Cable Jacket with Velcro (For 10' gun)
	1860008		Cable Jacket with Velcro (For 15' & 25' gun)
21	2520077		Strain Relief Assy, Miller
	2520076		Strain Relief Assy, Bernard
22	1010027		Adapter Block (Not Req'd on Bernard Direct Plug)
23	W11127-002		Strain Relief Screw (Not Req'd on Bernard Direct Plug)
24	<i>See Liner Spec Sheet</i>		Liner
25	<i>See Direct Plug Spec Sheet</i>		Direct Plug Components
NS	1880245		Vacuum Adapter Kit (Includes: (1) 2-1/8" to 1-1/2" threaded hose fitting, (1) hose clamp). Note: Use to connect gun to Miller Filtair 130 or other extraction units with similar threaded hose ID.