

# Quik Tip™ Series

## Nozzles, Tips, Diffusers

Issued March 2009 • Index No. SPEC QT-1.1

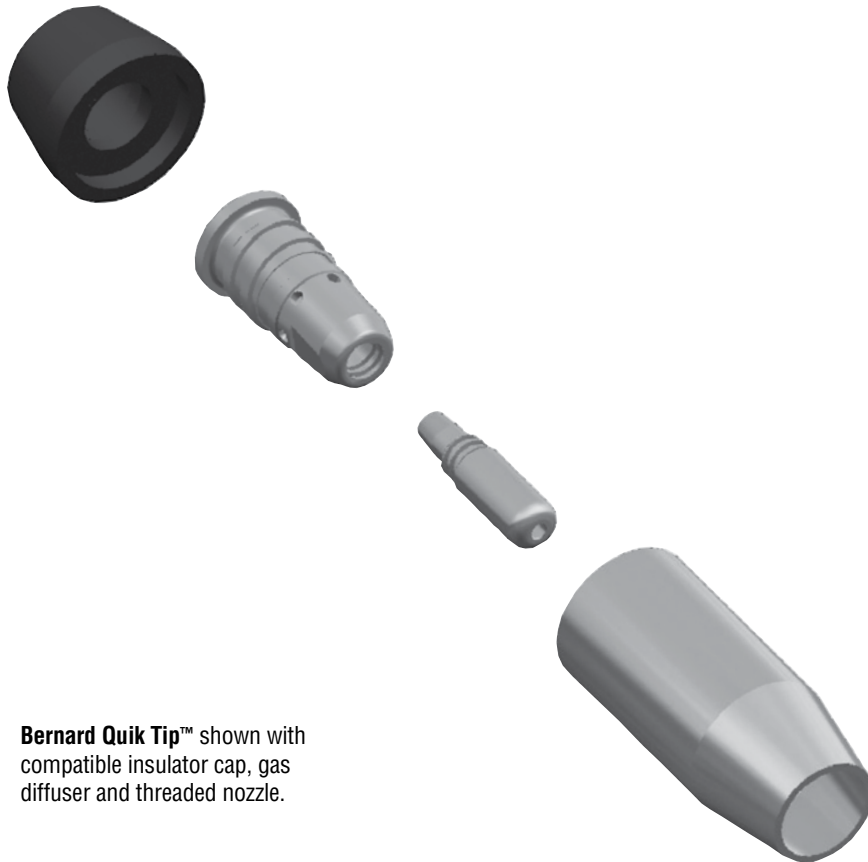

**Bernard Quik Tip™** shown with compatible insulator cap, gas diffuser and threaded nozzle.

### All Consumables are Not Created Equal.

It's important to choose longer lasting consumables. They can make the difference between repeated consumable replacement and rework, or more arc time and better bottom line.

**Quik Tips designed with threaded taper lock that increases tip life** by providing excellent heat transfer and electrical conductivity.

**A quick twist is all it takes to install Quik Tips.** In case of burn back, another quick twist will get you back on the job in moments.

**Gas diffusers have positive stops to secure Quik Tips in a fixed position** for superior repeatability and consistent, quality welds. Multiple fixed positions available.

**Nozzles available in threaded and slip-on styles** with a variety of orifice diameters for optimal shielding gas coverage.

**Fit all Q-Guns™ and S-Guns™ - from 150 - 600 Amps.**

Made with  
Pride and without  
Compromise in the **USA**

### Bernard®

An Illinois Tool Works Company  
449 West Corning Road, Box 667  
Beecher, Illinois 60401 USA

Phone: 800-946-2281 (US Only) 708-946-2281 (Outside US)  
Fax: 708-946-6726  
For more information, visit us at [BernardWelds.com](http://BernardWelds.com)



# Available Parts

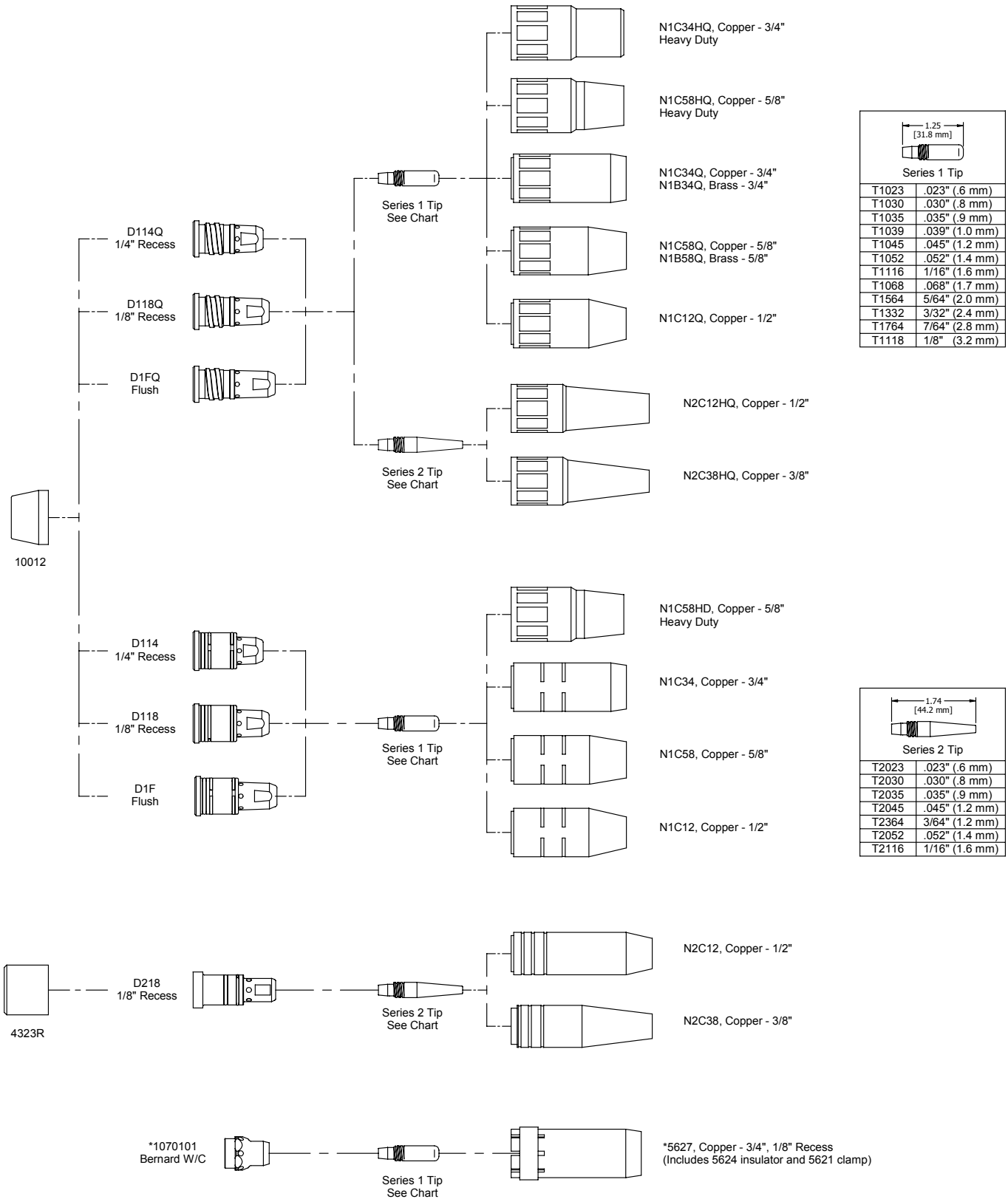

\*For use with Bernard Water-Cooled guns.